

# The Ham merhead

## *In this Issue:*

### ***Proposed 2004 Knowns***

### ***Kathy Jaffe Results***

### ***And More...***

#### **The Pitts Stop, by Steve Pennypacker IAC Chapter 35 President**



Pitts Stop Sept. 2003

This month I'll spare you from the lengthy verbage I've been spitting out for the last few months. Not that anyone actually reads this stuff anyway. This will be a pretty short column since I've got to head out to the left coast in a few hours and for whatever reason, there just doesn't seem to be that much news to relay.

Gatineau (Ottawa) and Monticello (Kathy Jaffe) were both held recently. A triad of enroute weather, holidays due to a conflict with the WAC, and the economy conspired to keep

Gatineau attendance low this year. Even so, Chapter 35 managed to take top honors in two of the three categories flown. I'm sure next year's attendance will be better. Monticello had a bigger bunch to duke it out, with Rob Holland making his usual habit out of prevailing over anyone else who dares show up in Advanced. I don't have full results but I do hear it was a great contest with great weather.

We've had to cancel the Springfield contest because the ramp is being torn up and repaved. I'm not sure whether this was a miscommunication or a change in plans at the state level, but either way it's the same result. The good news is that George Coy has signed up to run the contest again in 2004. Thanks, George! We may try to do something a bit less formal for one or both days that weekend, so hold your schedule open for now.

I've heard feedback from a few people that not everyone within or outside the chapter had heard the news of Ron Burns' passing. Please keep this in mind in any conversations you may have.

We're planning the Son of Outlaw at Plymouth later this year. Stay tuned.

Some local acro pilots held and attended a meeting in August regarding the noise issue. This affects everyone, whether a chapter member or not. If you're thinking it doesn't affect you, talk to someone who was at the meeting or give

me a call. It might save you some trouble.

Proposed 2004 Knowns are available for comment. They're printed later in this issue.

There are lots of proposed rule changes this year, many more than other recent years. If you're a competitor, judge, registrar, Chief Judge, or jury member - basically if you show up at a contest - these will affect you. Comments are taken up to October 1, after which the IAC board will consider the comments and vote on the changes. Feel free to not comment, but if you don't, you've got to accept the changes. Send comments to Brian Howard ([BK@NewAttAero.com](mailto:BK@NewAttAero.com) or (520) 360-7655) and to Howie Stock ([IACVP@aol.com](mailto:IACVP@aol.com) or (815) 338-4584). If you'd like send them to me and I'll forward with or without your name attached.

Well, I guess there was more to talk about than I thought.

Steve

### A Fun Day at Plymouth

Thanks to Bill Crawford, many of us got to enjoy the airport fun day at Plymouth airport. Folks gathered at Bill's front row hanger for BBQ and a great view of the mini air show. The air show featured the Iron Eagles, an impressive pair of Christen Eagles (actually Super Eagles with AEIO540s) doing an array of maneuvers side by side, tandem and sometimes head on! It was an impressive show. A parade of planes segment included Bill in his Airwolf and Sheldon in his Extra 300. A T6 flown by chapter 35's Reese Dill graced the skies as well. A jump team rounded out the show. Nice weather, good food and an entertaining show made for a great Sunday during Labor Day weekend. Thanks Bill!

### 2003 KJ Challenge in a Nutshell by Dave Watson and Hans Bok

The KJ Challenge started off like last year for me. Finding the wing root fairing of my Decathlon separated from the first rib is always a great way to start a contest. Fortunately I have a spare acro ride and I was able to secure Rob Holland's Decathlon for Mike Ganor. Flights of the Known on Friday were fairly uneventful for

MOST. For me however, the judges simply failed to properly reward the sudden 15-degree upward pitch attitude change that I used to signify the initiation of my spin. Snap-roll entry my butt! The Unknowns were flown as the second flight. That was interesting and for at least one chapter 35 blue-Laser pilot (who will remain un-named) flew some of the flight so that it was unknown even to the judges. Fortunately, he had a great Free on Sunday and was able to fight back and capture the Bronze. Then there was that Free on Sunday. Someone apparently snuck into Bill Gordon's cockpit and switched out the program card in his holder. That despicable act of treachery caused Bill to fly his old freestyle instead of the new one that he had submitted – OOPS. And to reward Bill for his beautifully flown, yet Unknown-Free he was awarded the Best Freestyle performance at the closing ceremonies. Rob Holland flew so well that several of the judges have formed a new group, Judges Anonymous. A not-for-profit organization that helps judges deal with the depression of having to say the word *tee... tin*, I mean *ton*, I mean .. greater than 9.5. As you can see my sessions are paying off. Speaking of Rob, the highlight of the Saturday banquet was when our cousins from New York honored Rob with a spectacular plaque for his contributions to the sport – His enthusiasm and contagious love of flying [well]. Rob's flight school posted nine, count 'em nine, new (and returning) pilots at the contest and several of the awards – keep up the great work. Ann Salcedo came up from Florida just to be the Volunteer Coordinator – Again. Wow – what a giving person. Thanks Ann. As a last word, I'd like to encourage you all to spend a moment and send Aviat a letter of appreciation for their support of our sport. I spoke with Danny Adams at the banquet and found that he goes to 29-32 contests a year!!! That is 3 out of 5 weekends away from his family all year long for the past 4 years. So many of us have been patched, fixed, or trimmed. It's hard to imagine how he keeps it up and impossible to quantify how much he has done. Thanks Danny.

Here are the results from the Kathy Jaffe Challenge.

Primary  
1st Douglas Lovell 52  
2nd Mary Gannon  
3th John Wood

Sportsman

- 1st Michael Henning 35
- 2nd Douglas Durand
- 3rd Gerald Hansen
- 4th Mike Ganor 35
- 5th Kendal Simpson 52
- 6th Andy Cooper 35
- 7th Tom Parsons 52
- 8th Weston Liu 35
- 9th Dan Freeman 11
- 10th Janusz Becla 35
- 11th John Homrok
- 12th Matt Crane

Intermed

- 1st Larry Bayshore 58
- 2nd William Matukaitis 35
- 3rd Steve McCalmont 35
- 4th Derek Dodds 52
- 5th Lloyd Suter 52
- 6th David Watson 35
- 7th Mark Stewart 34
- 8th Ray Moorman 35
- 9th Sheldon Apsell 35
- 10th Bill Green 52
- 11th Stephen Seidel 52
- 12th Bill Gordon 35
- 13th Ron Chadwick 52
- 14th Karen Greenfield 11
- 15th Peter Ashwood Smith

Advanced

- 1st Rob Holland 35
- 2nd Alex Belov 52
- 3rd Hans Bok 35
- 4th Bill Finagin 11
- 5th Dennis Thompson 52

Unlimited

- 1st Rick Volker 34
- 2nd Angelo Cillaroto
- 3rd Charles Kalko 52

The Aviat Trophy went to Rob Holland.

For Sale



**EXTRA 230**, 535 TT, 50 SMOH, Fuel totalizer, Electronic Oil Pressure & Oil Temp, Becker Comm, Garmin GPS, Sight Gauge. Price \$79.9K. Call Charlie (603) 885-6719, Hans (508) 994-5957

**SUKHOI-SU-29 1993**, impeccable, premoritorium, 314T.T., advanced category only, unique blue, white, red, gold paint, Northstar GPS, KX 125 nav/com, KT 76a w/encoder, T/B, smoke, pilot/copilot chutes, B/C alternator and battery, Champion plugs, all prop mods, intake drain system, aircompressor relief valve in cockpit, Cleveland brakes, Full wheel pants, hard rubber tail wheel, new engine mount rubbers(02), ailerons balanced by Nick T., hooker harnesses, complete tool kit and jacks, spare parts, detailed maintenance records/oil samples-one pilot history, no damage history-if you want the best call Art 800-540-7098, cell 207-776-1044, asking \$174,500 or best offer, brokers protected.

**Yak-55 available for import**, \$45k ready to go, well under the going rate. Contact George Coy at (802) 868-5633.



<b>B</b>	Contest: <b>PROPOSED</b>	Category: <b>Sportsman</b>
	Date: <b>2004</b>	Program: <b>Known</b>

wind direction Pilot

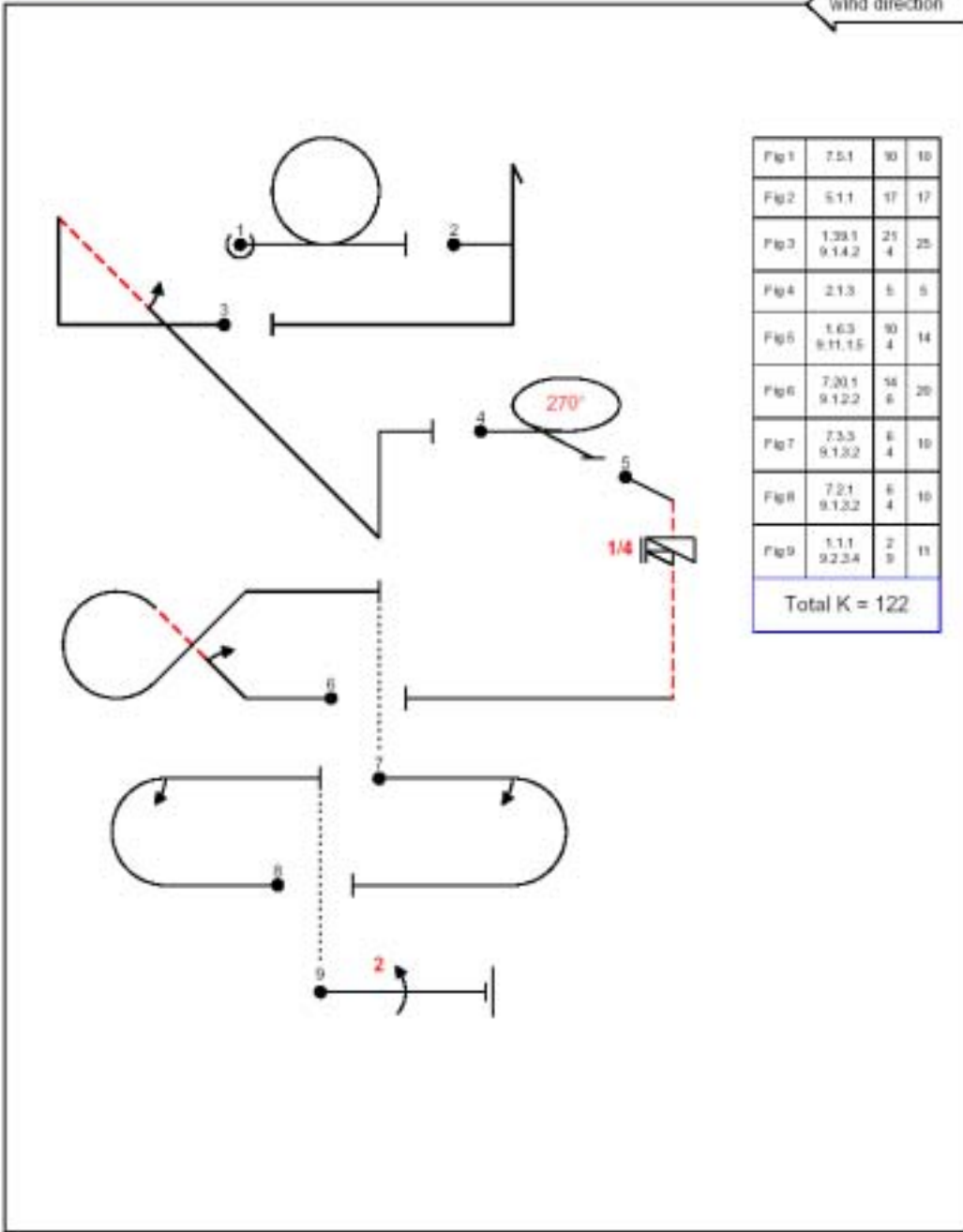

Fig 1	7.5.1	10	10
Fig 2	5.1.1	17	17
Fig 3	1.39.1 9.14.2	21 4	25
Fig 4	2.1.3	5	5
Fig 5	1.6.3 9.11.15	10 4	14
Fig 6	7.20.1 9.12.2	14 6	20
Fig 7	7.3.3 9.13.2	6 4	10
Fig 8	7.2.1 9.13.2	6 4	10
Fig 9	1.1.1 9.2.3.4	2 9	11
<b>Total K = 122</b>			

A/C:

(signature/date)

FREE PROGRAM CHECK BY:



<b>B</b>	Contest: <b>PROPOSED</b>	Category: <b>Intermediate</b>
	Date: <b>2004</b>	Program: <b>Known</b>

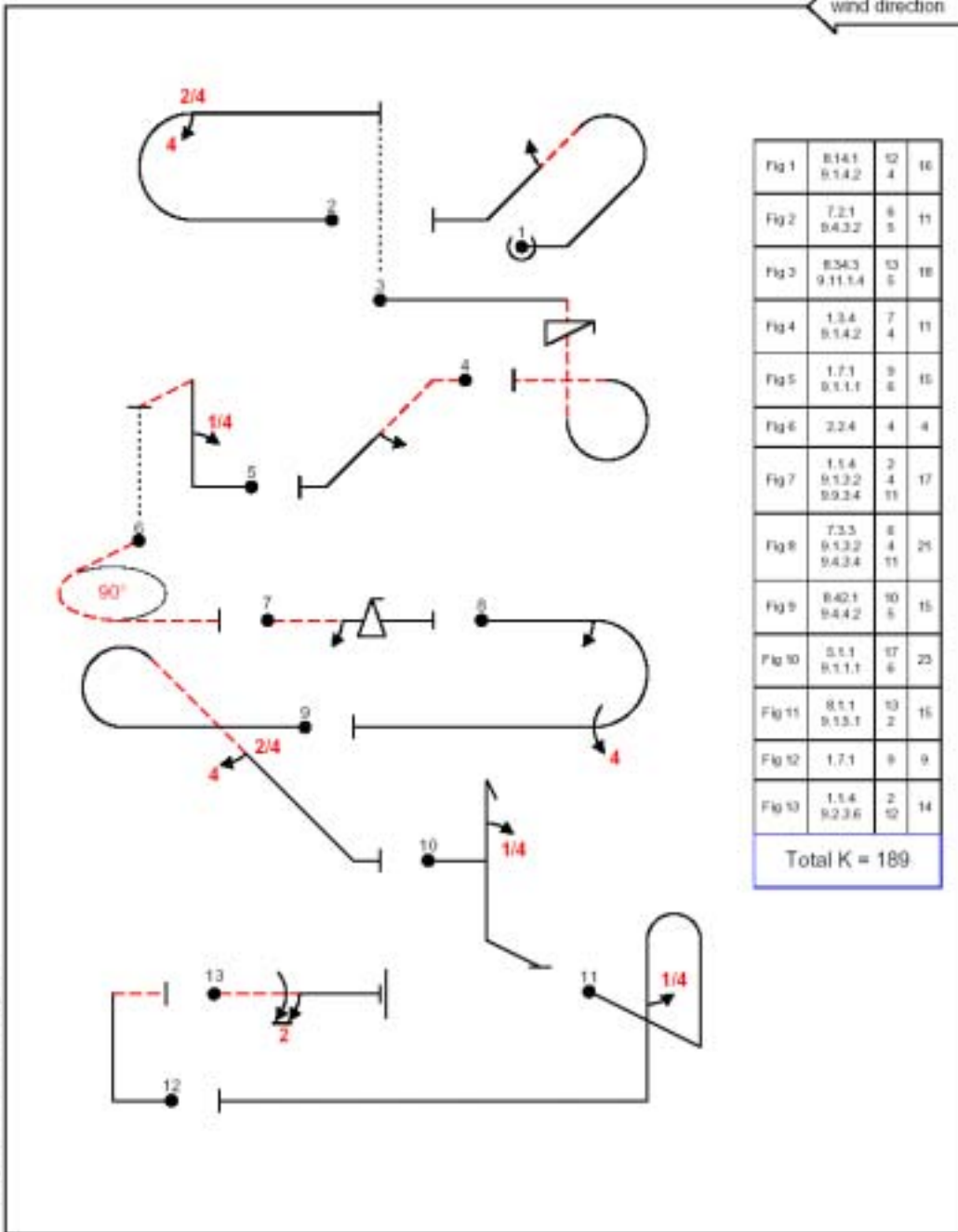

Fig 1	8.14.1 9.14.2	12 4	16
Fig 2	7.2.1 9.4.3.2	6 5	11
Fig 3	8.54.3 9.11.1.4	13 5	18
Fig 4	1.3.4 9.14.2	7 4	11
Fig 5	1.7.1 9.1.1.1	9 6	15
Fig 6	2.2.4	4	4
Fig 7	1.1.4 9.1.3.2 9.3.3.4	2 4 11	17
Fig 8	7.3.5 9.1.3.2 9.4.3.4	8 4 11	25
Fig 9	8.4.2.1 9.4.4.2	10 5	15
Fig 10	9.1.1 9.1.1.1	17 6	23
Fig 11	8.1.1 9.13.1	10 2	16
Fig 12	1.7.1	9	9
Fig 13	1.1.4 9.2.3.6	2 10	14
<b>Total K = 189</b>			

FREE PROGRAM CHECK BY: \_\_\_\_\_ (signature/date)

Created Using Aerial 6™ software. ACC@aerolag.com

**Chapter 35 – Officers**

President- Steve Pennypacker  
68 Pilgrim Road  
Holliston, MA 01746  
508-429-1171 H  
steve@pennypacker.org

Vice President- Steve Till  
779 North Road  
Carlisle, Ma. 01741  
(978) 369-8592 H  
setill@earthlink.net

Treasurer- Sheldon Apsell  
20 Malubar Lane  
Newton, MA 02459  
617-332-4795 H

Safety Officer- Craig Lesinski  
37 Berry Street  
Plainville, MA  
(508) 695-0002 H  
aerobatika@aol.com

**Calendar of Events**

September 21-26, 2003  
U.S. National Aerobatic  
Championships  
Sherman/Denison Texas

September 7  
Practice Day  
Plymouth, MA

October 3-5, 2003  
East Coast Aerobatic Contest,  
Warrenton VA

October 18  
Practice Day  
Littlebrook

November  
Wright Experience @ PYM  
Acro details TBA

**Chapter 35 - Web Site**  
**<http://acro.harvard.edu/IAC35>**

**Newsletter stuff goes to:**  
Rob Petit at  
**<mailto:rjpetit@earthlink.net>**

**Chapter 35 mailing list signup** (highly  
recommended):  
**[iac35-subscribe@yahoogroups.com](mailto:iac35-subscribe@yahoogroups.com)**